

Certified according to DIN EN ISO 9001

Technical Datasheet



VTM Local Display Unit with Frequency and Analogue Output

Description	3
Technical Data	3
Safety-relevant Data	4
Dimensional Drawings	5
Ordering Information	6
Notes	7
Marking	7

Index

Index

Description

The VTM is a programmable local display with integral carrier-frequency pickup and amplifier for KEM flow meters. It serves the evaluation of flow volumes. Measuring results are indicated in an 8 digit LCD display with 14 segments. A 10 point linearization is included to optimize the accuracy.

The pulse output provides a flow-proportional frequency signal or scaled volume pulse in accordance with programming. Optionally the measuring signal may be scaled in a 4–20 mA current loop. The electronic housing is slewable by 360°, in addition the display unit may be positioned in steps of 90°. This guarantees for an excellent readability independent of the installing position. For electrical connection a junction box with six internal terminals is provided.

Features:

- 10 point-linearization
- LCD-Display: 8 digit (14 segments)
- Ex-Approval: EX II 2 G EEx ia IIC T4

Technical Data

General	
LCD display	8 digits (14 segments), digit height 7 mm for real-time value, totals and programming, slewable in steps of 90° after loosening the fixing screws
Linearization	possible with 10 points
Ambient temperature	–40 up to +60 °C
Medium temperature	–40 up to +120 °C with a distance of at least 25 mm (for versions up to +150°C see ordering information page 6) between flow meter and electronic housing
Electrical connection	junction box with 6 internal terminals and adjustable cable sleeve 7–13 mm 1 = UB 2 = frequency output 3-wire 3 = 0 V 4 = -IA 5 = +IA 6 = shield
Ex-protection ATEX 100a	 II 2 G EEx ia IIC T4, BVS 03 ATEX E 205
Protection class	IP 65
Housing	aluminium AlMgSiPb, blue anodised, slewable by 360°
Weight	approx. 700 g

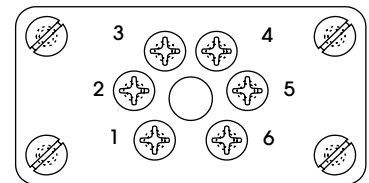

Frequency output/divider	
Operating mode	3-wire
Supply voltage	8–30 V DC controlled, Ex-protected versions: 12–30 V DC
Quiescent current (IR)	< 25 mA
Signal output	push/pull I_{max} : 20 mA 1. Frequency output: f_{max} : 3,000 Hz duty cycle: approx. 1:1 2. Divider: pulse width: 1 ms, 20 ms, 50 ms f_{max} : 500 Hz
Analogue output	
Operating mode	2-wire passive (4–20mA)
Supply voltage	14–30 V DC controlled $U_B = (R_{load} \times 20 \text{ mA}) + 14 \text{ V}$
Load	< 800 Ω
Resolution	12 bit (3,9 μ A)
Time constant	< 0.2–3 s (programmable)
Signal output	4–20 mA

Safety-relevant data

Three-wire supply and frequency signal current circuit

Supply: pins 1 (A) and 3 (C) or corresponding terminals

voltage U_i = DC 30 V
 current power I_i = 120 mA
 power P_i = 750 mW
 effective internal capacity C_i = \leq 26 nF
 effective internal inductivity L_i = 0

Frequency signal current circuit: pins 3 (C) and 2 (B) or corresponding terminals

voltage U_i = DC 30 V
 current power I_i = 500 mA
 power P_i = 750 mW
 internal resistance R_i = 1350 Ω , ± 5 %
 effective internal capacity C_i = \leq 13 nF
 effective internal inductivity L_i = 0

Two-wire supply and signal current circuit (4–20 mA current loop)

Pins 4 (D) and 5 (E) or corresponding terminals

voltage U_i = DC 30 V
 current power I_i = 120 mA
 power P_i = 750 mW
 effective internal capacity C_i = \leq 26 nF
 effective internal inductivity L_i = 0

Dimensional Drawing (mm)

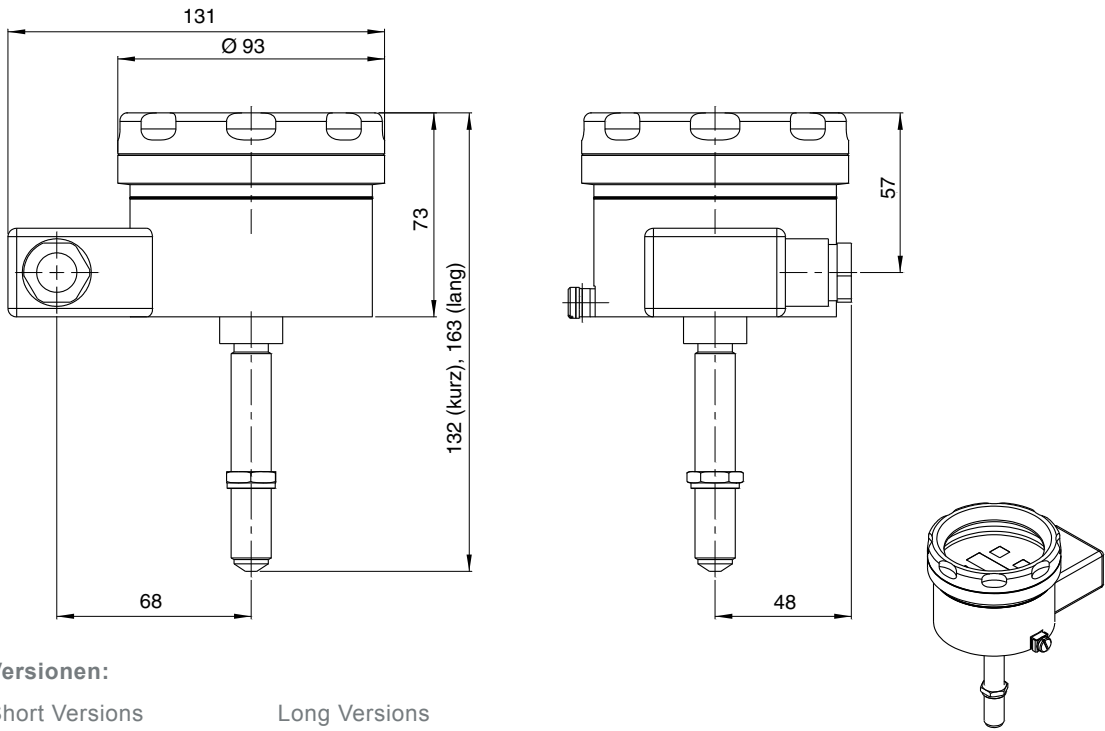

Versionen:

Short Versions	Long Versions
VTM B.D.K. ...	VTM B.D.L. ...
VTM B.D.R. ...	VTM B.D.S. ...

Signal flow and connection

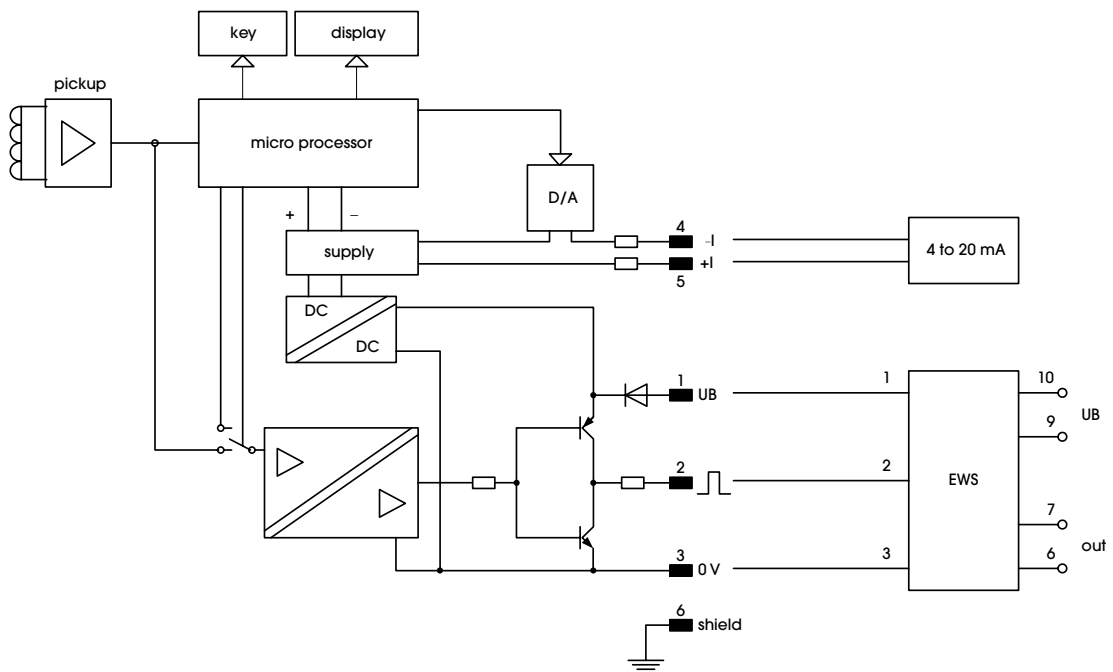

Ordering Information

VTM xxxxx-Ex-SS

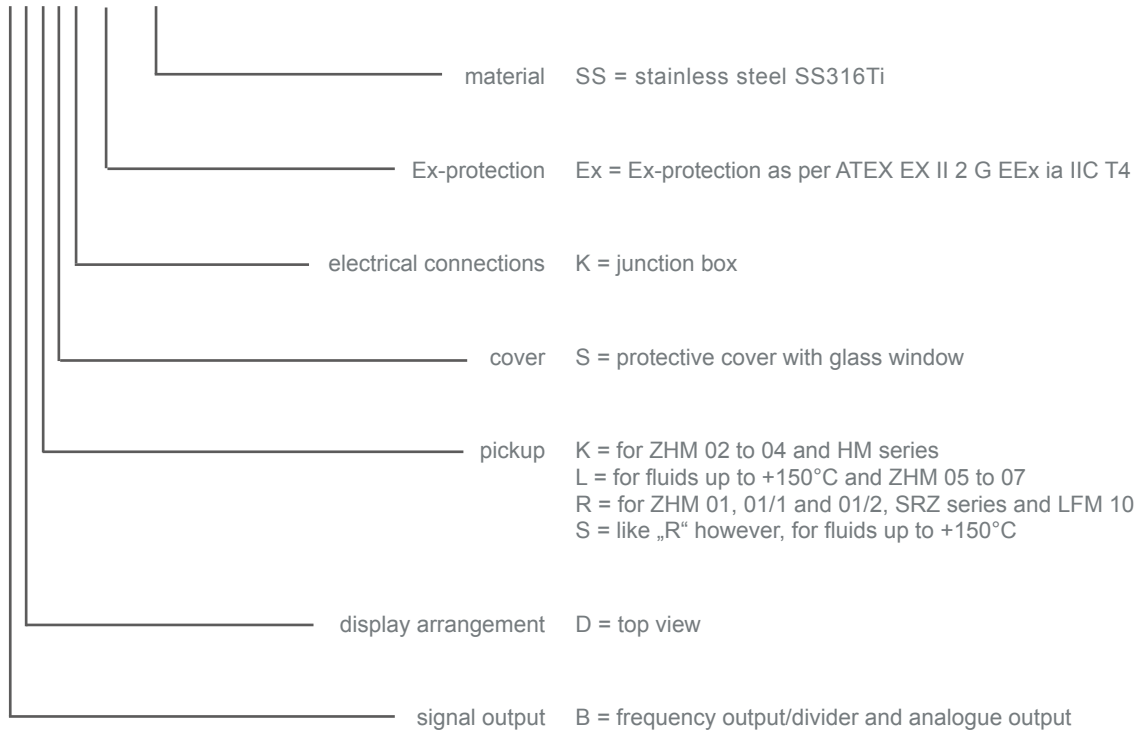

Notes

The following has to be adhered to:

- a) Installation instructions for electrical devices. Installation instructions for associated intrinsically-safe devices
The »Special conditions for safe use« as per EC-Type Examination Certificate
- b) The amplifier has to be installed in a way that the max. ambient temperature does under no circumstances exceed +60°C (consider self heating).
- c) With cables care should be taken, that the max inductivity and capacity of the respective voltage or gas group are not exceeded.
- d) Exceeding or falling below the regular measuring range will cause invalid frequency output signals.
- e) Shielded cables are to be used as connecting lines.
- f) Generally, supplied units have to be connected by an expert according to EMC stipulations.
- g) Flammable media may only be used as measuring medium when they do not build an explosive atmosphere permanently or for a longer period of time. In addition, the amount of air and oxygen contained must be low enough to ensure the danger of explosion can definitely be excluded. The local display unit has to be included in repeated pressure tests.

Marking and Safety Characteristics

Three-wire supply and frequency signal current circuit
Two-wire supply and signal current circuit (4–20 mA current loop)

KEM Küppers Elektromechanik GmbH

 0123  II 2G EEx ia IIC T4

BVS 03 ATEX E 205

Type Ser.Nr.

-40°C ≤ T_a ≤ 60°C

KL 1/3 U_i=30 V, I_i = 120 mA, P_i = 750 mW, C_i = 26 nF, L_i = 0

Contact worldwide

KEM-Headquarter

Liebigstraße 2
D-85757 Karlsfeld
T. +49 8131 5 93 91 - 0
F: +49 8131 9 26 04
info@kem-kueppers.com

KEM-Office West

Im Langen Hahn 44
D-58515 Lüdenscheid
T. +49 2351 9 78 80
F: +49 2351 9 78 83 1
kem-west@kem-kueppers.com

KEM-Office South

Dahlienweg 35
D-73765 Neuhausen
T. +49 7158 98 56 82
F: +49 7158 98 56 83
kem-sued@kem-kueppers.com

Denmark

E. Eberhardt ApS
Bygstubben 6
DK-2950 Vedbæk
T. +45/45/89 33 66
info@eeberhardt.dk

Norway

Flow Teknikk as
Olav Brunborgsv. 27, Postboks 244
N-1377 Billingstad
T. +47/66/77 54 00
mail@flow.no

Singapore

Polyquip Engineering Pte Ltd
Blk 20 Woodlands Link #08-12
Woodlands East Industrial Est.
SGP- 738733 Singapur
T. +65/6753/79 97
sales@polyquip.com.sg

China

KEM China
Mr. Xiao Tianxiang
Rm.2429, JinYuan Office Building, No. 36,
CN- BeiYuan Road, Beijing 100012
T. +86/10/52 00 37 38
Shaw@kem-kueppers.com

Poland

Newtech Engineering
ul. Sowinskiego 3
PL-4-100 Gliwice
T. +48/32/237 61 98
newtech@newtech.com.pl

Slovakia

Bibus SK, s.r.o.
Priemysel'na 4
SK-949-01 Nitra
T. +421/377/41 25 25
gyenes@bibus.sk

Finland

Wexon Oy
Juhanilantie 4
FI-01740 Vantaa
T. +358/9/29 04 40
wexon@wexon.com

Portugal

Contimetra Departamento Indústria
R. Braamcamp 88-40 Dt0
P-1269-020 Lisboa
T. +351/213/86 05 00
contimetra@contimetra.com

Spain

Ortrat S.L.
Calle La Sofora 13 + 15
ES-28020 Madrid
T. +349/1/57 91 60 6
ortrat@ortrat.es

United Kingdom & Eire

KEM Küppers UK
2 Highfield Drive
Ickenham Uxbridge
UB10 8AL England
T. +44/1895/23 35 52
hans.rader@kueppers.co.uk

Russia

Michael Dueck
Industrievertretungen und Vertrieb
St.-Vither-Str. 12
D-50171 Kerpen
T. +49/2237/67 91 88
info@m-dueck.de

Taiwan

Yuden Electric Co.,Ltd
Taiwan Headquarter
5F, No.121, Li De ST, JHONGHE TAIPEI
COUNTY 235, Taiwan ROC
T. +886/2/82 21 29 58
sales@yuden.com.tw

Hong Kong Area

Asia Technology and Instrument Ltd.
Unit 5, 9/F., Free Trade Centre
49 Tsun Yip Street, Kwun Tong
HK-Kowloon
T. +85/227/16 55 56
ati@ati.com.hk

Sweden

Pentronic AB
SE-590 93 Gunnebobruk
T. +46/490/25 85 00
info@pentronic.se

United States of America

AW-LAKE Company
Electronics for Instrumentation
8809 Industrial Dr.
Franksville, WI 53126, USA
T. +1/262/88 49 80 0
sales@aw-lake.com

Italy

Ingg. Vigo e Cova SAS
Piazzale Segrino 6/a
I-20159 Milano
T. +39/02/668 82 02
vigo.cova@vigocova.com

www.kem-kueppers.com
info@kem-kueppers.com