

Certified according to DIN EN ISO 9001

Technical Datasheet



SRZ Series Helical Flowmeters

Applications	3
Design and Principle	3
Technical Data	4
Dimensional Drawings	5
Pressure Drop	6

Index

Index

Application

Helical Flowmeters are mainly used for processing media with high viscosities. The innovative measuring principle excels through the very low pressure drop, minimal shear of the medium and high measuring precision.

The SRZ range is also particularly well suited for test rig applications, since variations in the viscosity caused by varying temperatures have little effect on measuring accuracy. The robust construction of the SRZ facilitates its use for abrasive media as well as contaminated materials, such as heavy heating oils. The choice of high specification materials guarantees longevity, minimal wear and excellent measuring results.

Design and Principle

Two highly accurate cycloid-shaped screw spindles mesh and rotate inside a cylindrical housing with two overlapping holes in the form of a figure 8, which forms the measuring chamber.

The medium flows in axial direction and rotates the spindles, it is forced along the measuring chamber bores by the profile of the spindles. This happens without pulsation and with minimum leakage. A pickup will inductively detect the rotational speed of the spindle pair through the housing via a pole wheel with a high number of gears. The speed of the spindles is absolutely proportional to the volume flow over a very wide range.

Pulses per volume unit will finally serve the evaluation (in addition an analogue signal 4 to 20 mA will be available when using the local display unit VTM. Please see pickup and amplifier datasheets). The K-factor (calibration factor) of the helical flow meter defines the exact pulserate per litre. We calibrate our flow meters to determine their K-factors, calibration records are part of delivery. When calibrating we consider as much as possible operating viscosities and customers' specifications.

Pickups and Amplifiers

The pickups are suitable for fluid temperatures up to +150°C and ambient temperatures up to +50°C (higher temperatures on request). Versions for double pulserate and reverse-flow detection are also available.

For detailed information on our pickups and amplifiers ask for data-sheets. The following types are available for our SRZ flow meters.

- VTER/P Carrier-Frequency Pickup and Amplifier
- VTES/P Carrier-Frequency Pickup and Amplifier
- VTM Local Display Unit with frequency and analogue output 4 to 20 mA

Applications

- Polyurethane and polymer
- Glues and sealing materials
- Heavy fuel oil
- Petrochemical products
- Thixotropical fluids
- Fat and oils with varying viscosities
- Hydraulic test rigs with varying viscosities and fluids

Specials:

- High accuracy
- Wide measuring ranges 1:100, 1:400
- Suitable for pressures up to 400 bar
- Largely independent of viscosity, perfect for 30 up to 10⁶ mm²/s
- Low pressure drop compared with other positive displacement meters
- Double pulse rate and reverse-flow detection possible
- Pulsation-free measurement, non-sensitive to pulsating flows
- Ex-protection EExialICT6 for zone 1
- Resistant to corrosion by advanced materials and bearings
- Low operating noise

Technical Data

SRZ Series Helical Flowmeters	
Linearity	± 0,50% of actual flow value (from 30 mm ² /s onwards) ± 0,25% of actual flow value (from 100 mm ² /s onwards)
Repeatability	± 0,10%
Operating Pressure	PN 16/40 up to PN 400
Temperature	up to +150°C fluid temperature (higher temperatures on request)
Viscosity	30 up 10 ⁶ mm ² /s (below 30 mm ² /s with restricted measuring range and vertical mounting position)
Materials	housing: standard: stainless steel as per DIN 1.4305 (SS303) special: 1.4404 (SS316L) helicals: standard: stainless steel as per DIN 1.4122 (SS303) special: 1.4460 (SS329)

Type	Measuring range ltr./min	K-factor pulses/ltr.	Frequency range in Hz
SRZ 10	0.01 to 4	16,500	3 to 1,000
SRZ 20	0.04 to 16	9,000	6 to 1,250
SRZ 40	0.40 to 40	3,500	20 to 1,750
SRZ 100	1.00 to 100	850	8 to 1,750
SRZ 400	4.00 to 400	214	14 to 1,800

The measuring ranges are based on a viscosity of 30 mm²/s

K-factor and frequency figures are average values - the individual figures are recorded during calibration (see datasheet »SRZ...*.C.*« for versions with double pickup).

Please note different pulse rates and frequency ranges for high temperature versions:

SRZ 10: 11.200 pulses/ltr. and 2 up to 760 Hz
SRZ 40: 1.750 pulses/ltr. and 11 up to 1.167 Hz

Dimensional Drawings

SRZ*-Double Pickup:

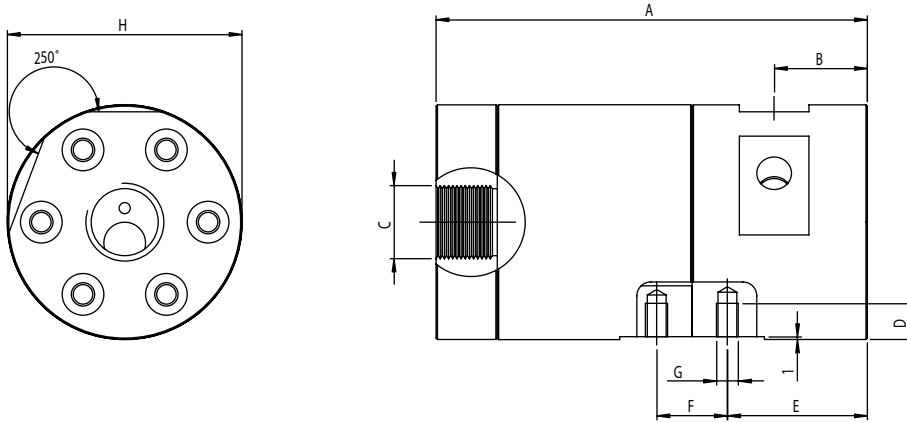

SRZ*-Single Pickup:

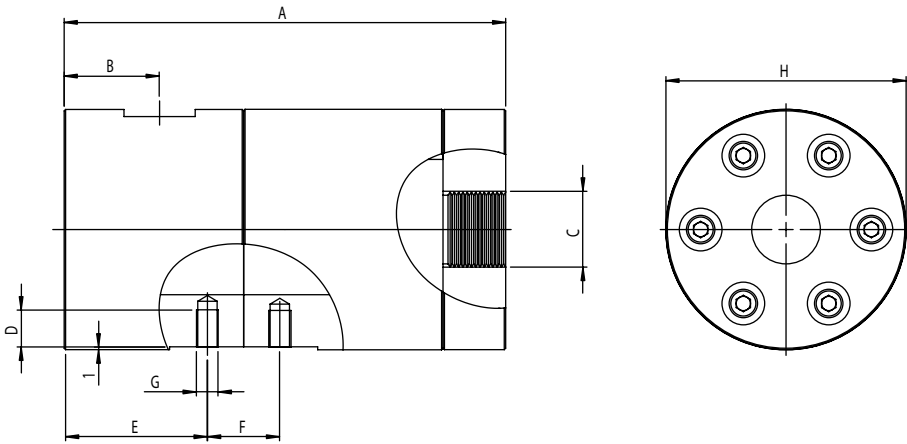

Dimensions

Type	A	B	C	D	E	F	G	H
SRZ 10	110	20	G1/4" / G3/8"	-	-	-	-	60
SRZ 20	117	30	G1/2"	-	-	-	-	76
SRZ 40	155	33	G3/4" / M22x1.5 / 3/4" NPT	13	50	25.4	M8	85
SRZ 100	221	41	G1" / 1" NPT	18	65	44	M10	110
SRZ 400	318	60	G1.5"	-	-	-	-	134

Pressure Drop:
in bar (average values)

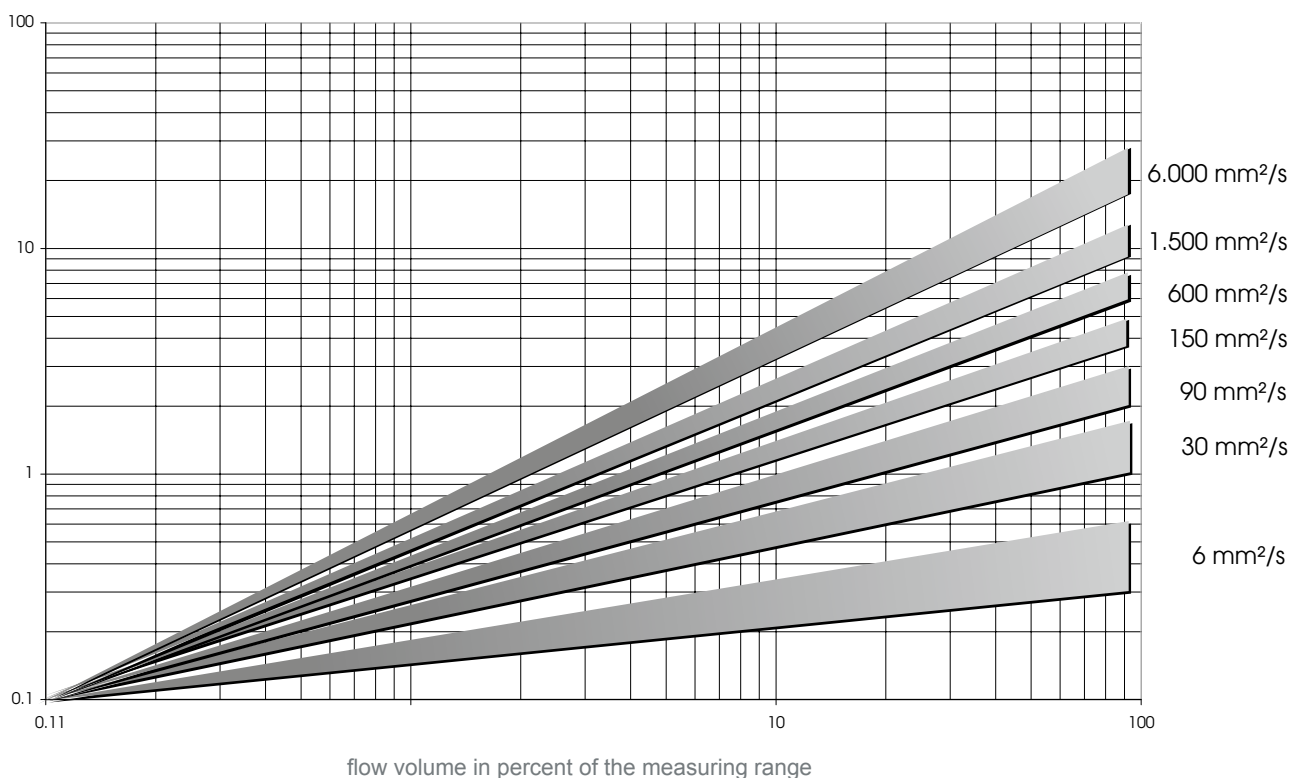

SRZ 10	0,04	0,4	4	ltr./min
SRZ 20	0,16	1,6	16	ltr./min
SRZ 40	0,4	4,0	40	ltr./min
SRZ 100	1,0	10,0	100	ltr./min
SRZ 400	4,0	40,0	400	ltr./min

Contact worldwide**KEM-Headquarter**

Liebigstraße 2
D-85757 Karlsfeld
T. +49 8131 5 93 91 - 0
F: +49 8131 9 26 04
info@kem-kueppers.com

KEM-Office West

Im Langen Hahn 44
D-58515 Lüdenscheid
T. +49 2351 9 78 80
F: +49 2351 9 78 83 1
kem-west@kem-kueppers.com

KEM-Office South

Dahlienweg 35
D-73765 Neuhausen
T. +49 7158 98 56 82
F: +49 7158 98 56 83
kem-sued@kem-kueppers.com

Denmark

E. Eberhardt ApS
Bygstubben 6
DK-2950 Vedbæk
T. +45/45/89 33 66
info@eeberhardt.dk

Norway

Flow Teknikk as
Olav Brunborgsv. 27, Postboks 244
N-1377 Billingstad
T. +47/66/77 54 00
mail@flow.no

Singapore

Polyquip Engineering Pte Ltd
Blk 20 Woodlands Link #08-12
Woodlands East Industrial Est.
SGP- 738733 Singapur
T. +65/6753/79 97
sales@polyquip.com.sg

China

KEM China
Mr. Xiao Tianxiang
Rm.2429, JinYuan Office Building, No. 36,
CN- BeiYuan Road, Beijing 100012
T. +86/10/52 00 37 38
Shaw@kem-kueppers.com

Poland

Newtech Engineering
ul. Sowinskiego 3
PL-4-100 Gliwice
T. +48/32/237 61 98
newtech@newtech.com.pl

Slovakia

Bibus SK, s.r.o.
Priemysel'na 4
SK-949-01 Nitra
T. +421/377/41 25 25
gyenes@bibus.sk

Finland

Wexon Oy
Juhanilantie 4
FI-01740 Vantaa
T. +358/9/29 04 40
wexon@wexon.com

Portugal

Contimetra Departamento Indústria
R. Braamcamp 88-40 Dt0
P-1269-020 Lisboa
T. +351/213/86 05 00
contimetra@contimetra.com

Spain

Ortrat S.L.
Calle La Sofora 13 + 15
ES-28020 Madrid
T. +349/1/57 91 60 6
ortrat@ortrat.es

United Kingdom & Eire

KEM Küppers UK
2 Highfield Drive
Ickenham Uxbridge
UB10 8AL England
T. +44/1895/23 35 52
hans.rader@kueppers.co.uk

Russia

Michael Dueck
Industrievertretungen und Vertrieb
St.-Vither-Str. 12
D-50171 Kerpen
T. +49/2237/67 91 88
info@m-dueck.de

Taiwan

Yuden Electric Co.,Ltd
Taiwan Headquarter
5F, No.121, Li De ST, JHONGHE TAIPEI
COUNTY 235, Taiwan ROC
T. +886/2/82 21 29 58
sales@yuden.com.tw

Hong Kong Area

Asia Technology and Instrument Ltd.
Unit 5, 9/F., Free Trade Centre
49 Tsun Yip Street, Kwun Tong
HK-Kowloon
T. +85/227/16 55 56
ati@ati.com.hk

Sweden

Pentronic AB
SE-590 93 Gunnebobruk
T. +46/490/25 85 00
info@pentronic.se

United States of America

AW-LAKE Company
Electronics for Instrumentation
8809 Industrial Dr.
Franksville, WI 53126, USA
T. +1/262/88 49 80 0
sales@aw-lake.com

Italy

Ingg. Vigo e Cova SAS
Piazzale Segrino 6/a
I-20159 Milano
T. +39/02/668 82 02
vigo.cova@vigocova.com

www.kem-kueppers.com
info@kem-kueppers.com