

KPS Turbidity Meter

User's Manual



Küppers Elektromechanik GmbH
Quality system certified to DIN ISO 9001

Contents

Product description page 3
Technical data page 3
Dimensions..... page 4
Getting started..... page 5
Electrical connections page 5
Operation page 6
Calibration verification or test page 7
Calibration procedure page 8
Typical responses page 10
Sensor offset and span calibration..... page 11
Examples for a multi-point calibration page 11
Installation page 12
Warranty page 13

Product Description

KPS is an in-line optical sensor that mounts directly to the process line, and provides real-time information about the process. KPS emits a beam of NIR light into the product, and in turn, measures the amount of backscatter produced by solids suspended in the product. The resulting degree of light scatter is converted to a 4-20 mA signal output.

Using the above operating principals, KPS can accurately detect the point of transition from water to product. This is considered the primary application. Depending on the degree of solids difference between two materials, a product-to-product transition may also be detected. And for products such as skim, 1 percent, 2 percent and whole milk, KPS can act as a monitor of milkfat percentage and an indicator of product quality.

The most common calibration entered into KPS includes points for water, skim milk, 1percent milk, 2 percent milk, whole milk and a maximum response standard equal to 20 mA.

Technical Data

Mechanical

Materials:	316-series stainless steel housing and fittings; sapphire and FDA-approved silicone product contact surface
Dimensions:	see next page
Connections:	Varivent®, Milchröhr oder Tri-Clamp
Weight:	1.4 kg (approx.)
Ratings:	NEMA 4X (water-tight, corrosion proof); authorized to carry 3-A symbol (Standard 46-03)
Optical Lens:	uncoated, optical sapphire (aluminum oxide) min. thickness = 2.3 mm minimum distance to the process stream: 5 cm
Lens Seal:	60 durometer, FDA approved silicone rubber (meets ZZR-765-E, Class 2 A&B)
Lens Surface Finish:	0.1 microns/inch £

Performance/Electrical

Accuracy:	±0.2% of span at 4.00 mA (water)
Repeatability:	±1.0% of span in any target fluid
Process Temp Range:	0 up to +100°C (continuous), intermittent +149°C
Process Temp Shock:	withstands instantaneous changes of up to 52°C (e.g. from 4.4 to 74°C during CIP, or from 52 to 121°C during SIP)
Temperature Effect:	0.9% of span/-12°C (process and/or ambient) maximum
Process Pressure Limits:	vacuum to 13.8 bar at rated temperature
Output:	4-20 mA, 3-wire
Power:	15-24 VDC, at 35 mA
Connection:	5 pin, water-tight, with quick disconnect cabling

Dimensions (mm)

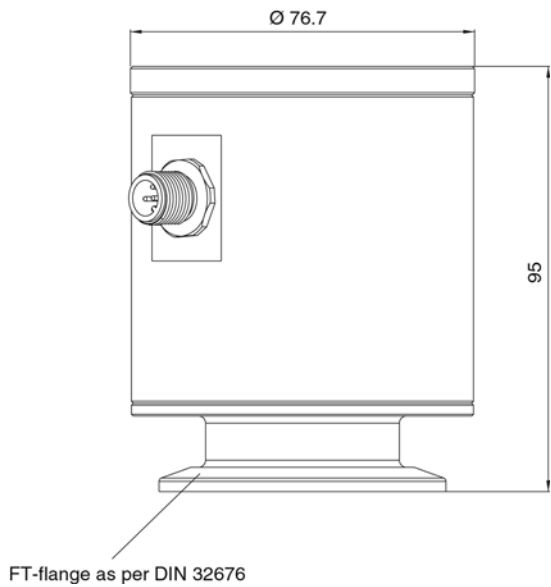

Tri-Clamp

Typ	Ø FT-flange
KPS 1.5	50.4 mm
KPS 2.0	63.9 mm
KPS 2.5	77.4 mm
KPS 3.0	90.9 mm

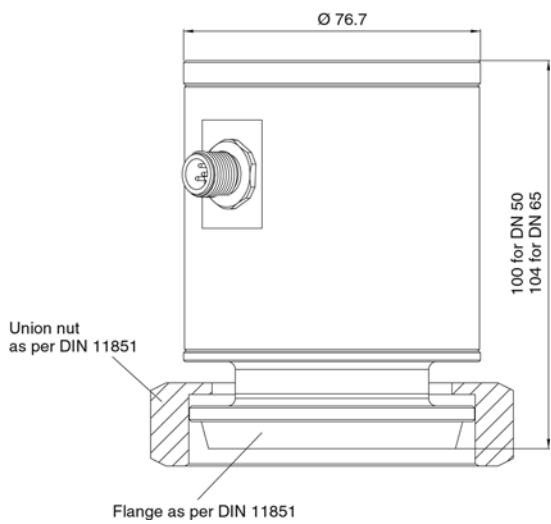

Dairy connections

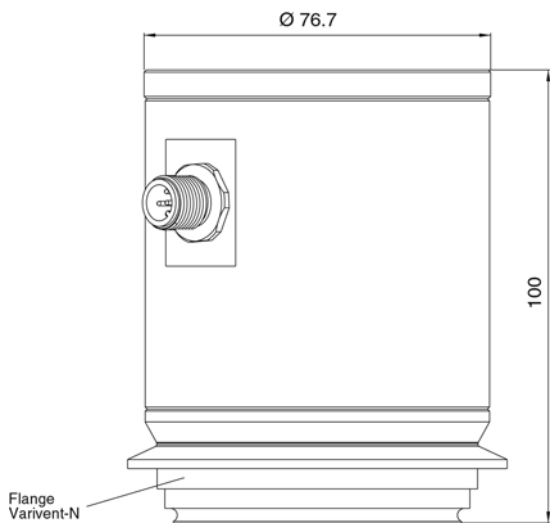

VARIVENT®

KPS – Getting Started

Unless otherwise specified by the customer, the sensors are shipped with a standard calibration covering a span of 4 to 20 mA and representing clean water at 4 mA and a maximum white standard at 20 mA. A calibration document will be included in the shipment to inform you of the calibration date and details.

Upon receipt of the shipment, carefully remove all items from the shipping package and ensure the contents are complete against the shipping documents.

Also please check the KPS sensor and other components for any damage that may have occurred during shipping. Make sure the sapphire lens is clean and undamaged. If it needs to be cleaned, you may use a mild soap solution and soft, clean cloth to gently clean the lens. Also check the sensor's electrical connector; it should easily mate with the connector pins on the sensor body. The threaded collar should also allow a snug, secure fit when fully engaged.

Electrical Connections

KPS has a 5-pin plug

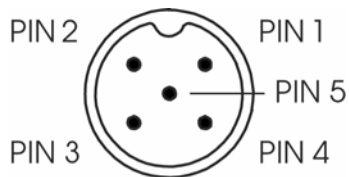

PIN 1 = -mA (brown wire)
PIN 2 = +mA (white wire)
PIN 3 = UB 15 to 24 VDC (blue wire)
PIN 4 = GROUND (black wire)
PIN 5 = nc

5-pin socket

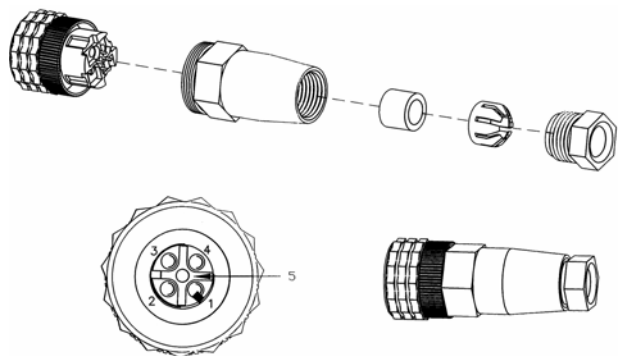

The most common wiring scheme for KPS is a 3-wire connection – pin 2 is the mA output, pin 3 is the 15 to 24 VDC power supply and pin 4 is the ground (negative side of the supply).

Pin 1 is the negative side of the mA output and is connected internally to pin 4. This is done to make it more convenient for users who want to make a 4-wire connection. pin 5, located in the center of the connector, is not used.

Once the connections have been made inside the electrical connector, make sure to tighten the threaded cord grip on the connector. This will help keep moisture from entering the connector.

Operation

Once KPS has been calibrated and the proper electrical connections have been made, the sensor is ready for operation. Before attaching the sensor to the process line, however, it is advisable to perform a quick check of the unit's operation.

The sensor output must be connected to a digital display, multimeter or some other electronics that will allow the user to monitor the KPS mA output.

When power has been supplied to the KPS sensor, the green LED on the unit's internal electronics board will blink. To view this board, remove the screw cap on the sensor. *Please note:* When the sensor is operating within the current calibration range, the green LED on the sensor's electronics board will blink alone. When over-range, the red and green LED's will blink and when below range, the green and yellow LED's will blink.

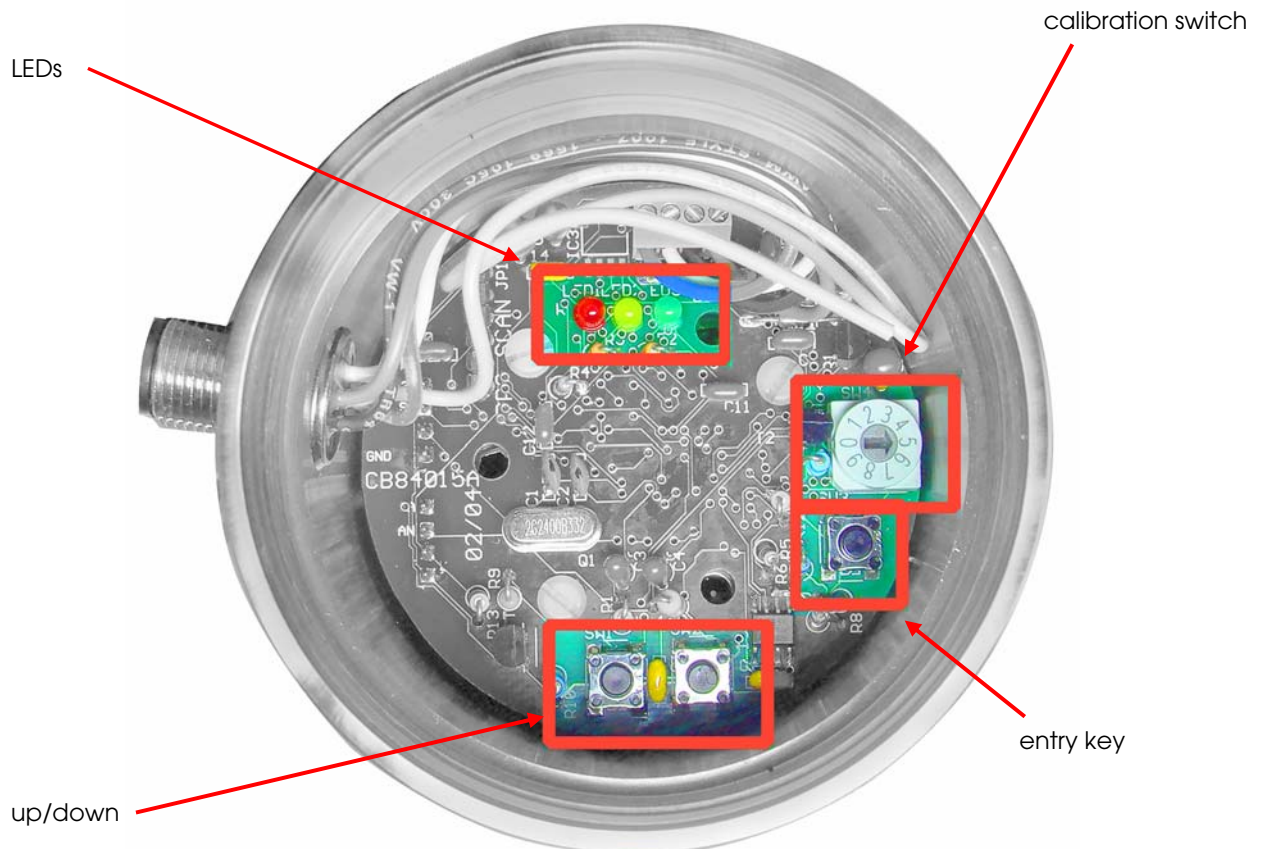

Begin by placing a white paper towel on a table. Next, with the lens facing down, place the sensor on the towel. This should produce an output of approximately 17 mA. The actual output may range from 16 to 19 mA; this is normal.

Next, lift the sensor straight up approximately 5 cm above the towel. This should yield a signal of 4 to 4.5 mA. Now slowly lower the sensor back to the towel; the mA output will increase as the sensor gets closer to the towel, eventually reaching approximately 17 mA.

If your sensor performs as stated, it is ready for installation. If not, call the supplier for technical assistance.

Calibration Verification or Test with Your Samples

KPS is normally calibrated at the factory according to the customer's specifications. If it is desirable to check or adjust the calibration on site, the user can do so by following these instructions:

Connect KPS to the required power supply and display with mA input. Attach the sensor to a suitable test stand, such as a sanitary tee. A common set-up is to close off the bottom leg of the tee with an end cap, attach KPS to the middle leg, and pour the sample in the top leg.

In most cases, the factory calibration is sufficient for your application. If you simply want to verify the calibration or determine the sensor's response on your samples, follow the steps below and record the KPS response. Be careful not to dilute or otherwise contaminate the samples between readings. Also, if the highest degree of accuracy is desired, make sure the samples are at the same temperature as they will be in the process line.



1. First, obtain samples of all products that will be processed in this system. You will need enough of each to fill a tee as shown.
2. Be sure the unit is properly wired to either the receiver, or to a Multi-meter, so that you are able to view the corresponding signal output from the unit. When power has been supplied to the unit, the green LED on the electronics board will blink.
3. Starting with the product containing the least amount of solids or of lowest turbidity, fill the tee as described above.
4. Record the output for this product, then move to the next, ending with the product containing the greatest amount of solids. *Please note:* When the sensor is operating within the current calibration range, the green LED on the sensor's electronics board will blink alone. When over-range, the red and green LED's will blink and when below range, the green and yellow LED's will blink.
5. The resulting profile will correspond to the outputs from the unit at each of the various products. These values can now be used as the reference for programming a receiver or to verify calibration of the KPS sensor. Changes in product properties (solids content) are a common cause for discrepancy. If observed, follow the CALIBRATION section of this manual (see next page).

Calibration Procedure

If you want to adjust the calibration, first remove the KPS lid by turning it counterclockwise. This will allow access to the KPS electronics board. Next assemble the desired calibration fluids. It is advisable to calibrate them in increasing order of concentration. KPS allows you to choose a variety of calibrations, from a 2-point calibration to a 9-point calibration.

1. First obtain samples of all products that will be processed in this system. If using liquid sample, you will need sufficient volume of each to fill the tee.
2. Be sure the unit is properly wired to either the receiver, or to a multimeter, so that you are able to view the corresponding signal output from the unit.
3. Remove screw cap on sensor. Use caution so as not to damage rubber o-ring. Refer to the picture shown on page 6 to locate calibration switch, entry key and offset adjustment keys (up/down).
4. As shown, fill the tee with clean water, or another fluid that you desire to be the 4 mA reference (if a value other than 4 mA is desired for the base value, please see SENSOR OFFSET and SPAN CALIBRATION section, page 11).
5. Observe the mA reading that KPS produces with the 4 mA reference sample. If the output is 4 mA, there is no need to adjust. If you desire to change the zero point, turn the calibration switch to position "0", and press and hold the ENTRY key for approximately two seconds. This will store the new value as 4 mA.
6. Remove the water, or optional base product, and fill the tee with the next highest solids content. So as not to introduce error in calibration, it is recommended that the tee be rinsed with water to clean any residue of the previous product from the face of the sensor.
7. Turn the CALIBRATION SWITCH to position 1. Press and hold the ENTRY key for approximately two seconds. The sensor output will now be set to 20.00 mA (or the span setting).
8. Repeat step 7, incrementing the CALIBRATION SWITCH by one, until all points have been calibrated – maximum is to point 8. As points are added, each addition becomes the new 20.00 mA top end. Each previously entered point is linearly re-scaled (see graphic next page).
9. In general, a five (5) point calibration is sufficient to provide proper output resolution. You may use calibration point 0 to 8. Point 9 is reserved for the Sensor Output Reference, described below.
10. To verify output values, the sensor should be placed again into each of the test liquids. With each product, record the resulting current output from the transmitter. The resulting profile will correspond to the outputs from the unit at each of the various products. These values can now be used as the reference for programming a receiver.

In accordance with the no. of calibration points the analogue span is divided into corresponding intervals:

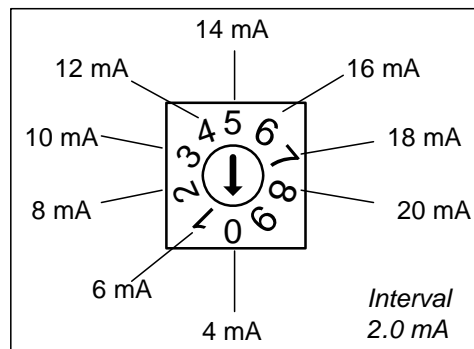
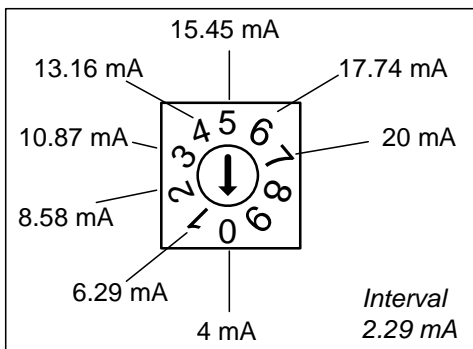
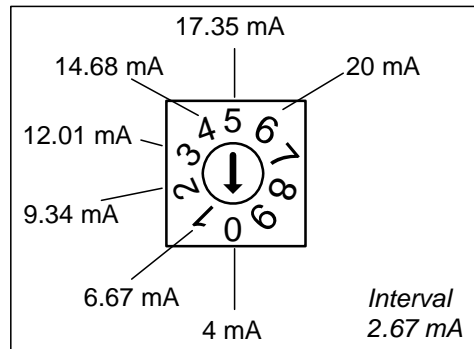
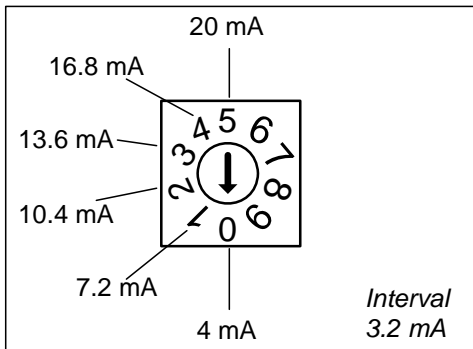
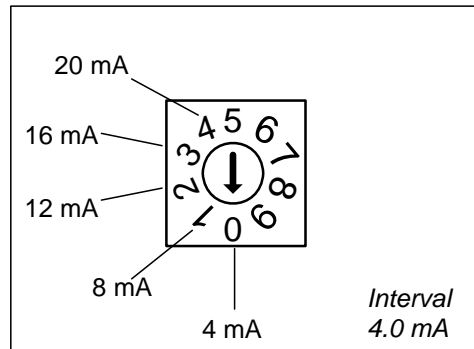
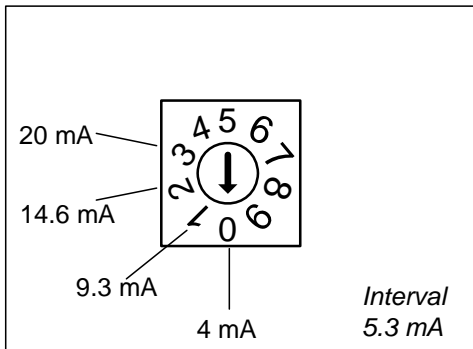
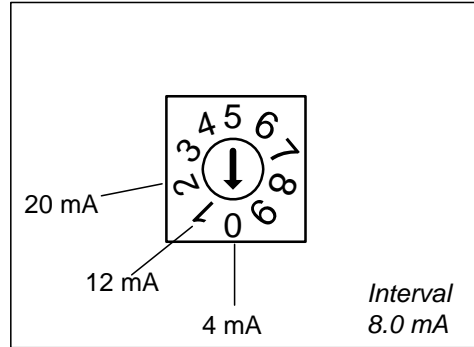
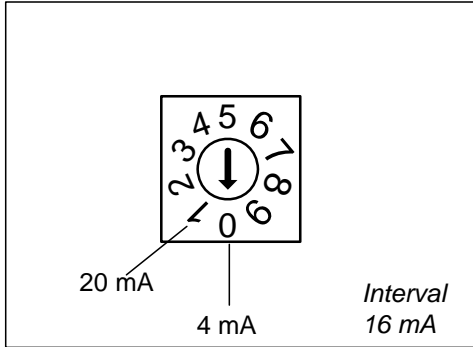

Typical Responses on various Dairy Products

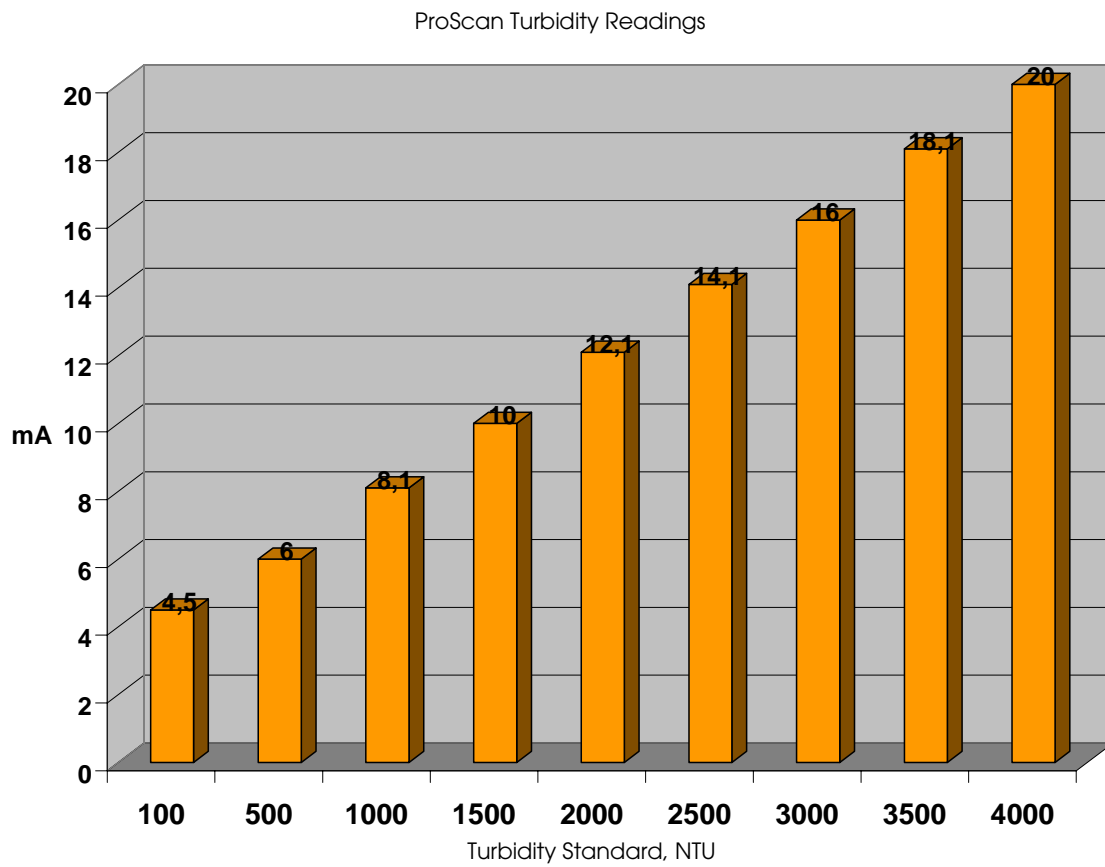
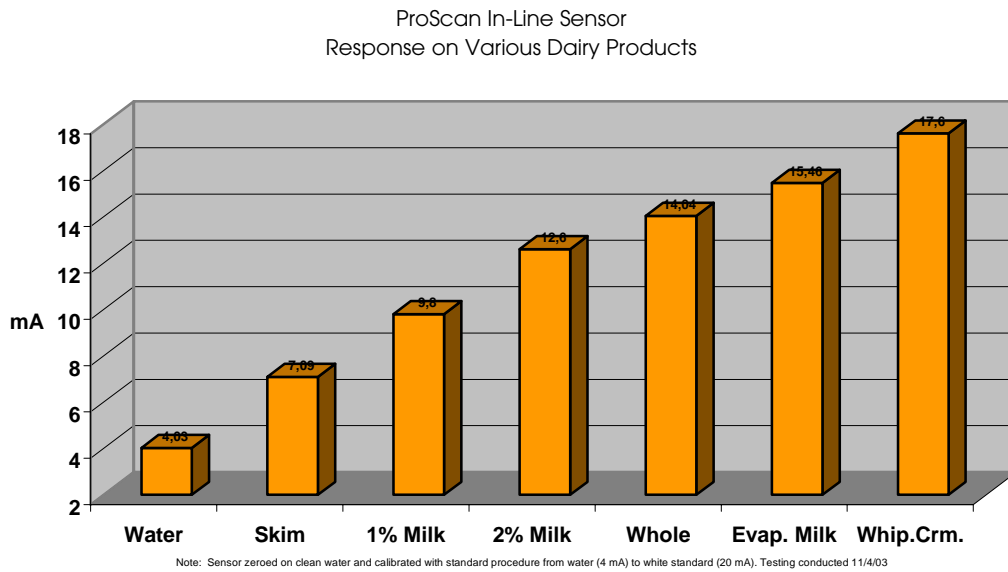

Sensor Offset and Span Calibration

The KPS sensor is typically prepared at the factory with a default value of 4.00 mA output for the “base reference” position “0”, and 20.00 mA for span position “9”. For most applications, it is recommended that the unit be used in this configuration. The following procedure illustrates steps to either verify, or modify these values.

1. Remove the screw cap on sensor. Use caution so as not to damage rubber o-ring. Refer to the picture shown on page 6 of this manual to locate calibration switch, entry key and offset adjustment keys.
2. If you wish to change the span value place Calibration switch in Position “9” and simply press the “up” or “down” offset adjustment keys until desired value is obtained, then press and hold the ENRTY key for approximately 2 seconds.
3. If you wish to change the “base reference” value place Calibration switch in Position “0” and simply press the “up” or “down” offset adjustment keys until desired value is obtained, then press and hold the ENTRY key for approximately 2 seconds.

Examples for a Multi-Point Calibration

For this example, milk samples were used. Water = 4 mA, skim milk = 8 mA, 1% milk = 12 mA, 2% milk = 16 mA and whole milk = 20 mA. The calibration selector switch was 0 position for water, 1 position for skim milk, 2 position for 1% milk, 3 position for 2% milk and 4 position for whole milk.

Calibration point	Calibration switch	Medium	Fat in %	Analogue out (mA)
1	0	Water	0	4
2	1	Skim Milk	0.5	8
3	2	Milk	1	12
4	3	Milk	2	16
5	4	whole milk	3.5	20

A slightly different example of a multi-point calibration is shown now. In this case a dairy customer wanted a greater degree of sensitivity near 1% milkfat; a 6-point calibration was used which emphasized the 1% to 1.3% milkfat concentration. All that was necessary was to prepare samples of the proper concentration. The KPS calibration linearizer divided the 4 to 20 mA span into five sections of 3.2 mA each, including the key range in the middle of the graph.

This illustrates how the KPS calibration can be tailored to meet different process control needs.

Installation

KPS has a conventional sanitary clamp connector that attaches directly to a tee or saddle in the process line or vessel. KPS comes in standard 1.5, 2, 2.5 and 3 inch sizes.

KPS can be successfully installed in a wide variety of configurations, including vertical and horizontal process lines and tanks. To optimize the performance of the sensor, it is important to keep the deadleg as short as possible on the tee connection and choose an installation site that will minimize air or sediment from collecting on the sensor's lens.

Deadleg - It is advisable to have the tee cut back so the KPS lens is as close as possible to the process stream and deadleg is minimized. Nevertheless, keep a minimum distance of 5 cm. In most cases, it is possible to cut the tee back and have a resulting deadleg of 1 to 2 inches. When it comes to deadleg, the shorter the better.

Installation Site - It is important to select an installation site and orientation that will minimize the possibility that air or sediment will interfere with the sensor's readings.

Vertical sections of process lines offer excellent installation sites, whether the flow is down or up. Another excellent installation site is a 90 degree elbow on a horizontal line; position the KPS so the process fluid flows directly at the sensor's lens.

If installed on a straight section of horizontal process line, it is advisable to place KPS so it looks sideways into the process stream, not up or down.

Two installations that are *not recommended* are on the top of horizontal process lines, where air has a tendency to accumulate, and on the bottom of horizontal process lines, where sediment can accumulate.

The clamp connection requires a gasket between KPS and the tee. In most cases, the customer provides the gasket and the tee. These products can be supplied on request.

Connect the sensor to the process pipe with the appropriate sanitary gasket and clamp.

Important: The sapphire lens can be damaged if struck by sharp or hard objects or if the sensor is dropped during installation. Take care when connecting the sensor to the tee so that the lens is not damaged.

It is advisable to orient the sensor so that the electrical connector points toward the floor.

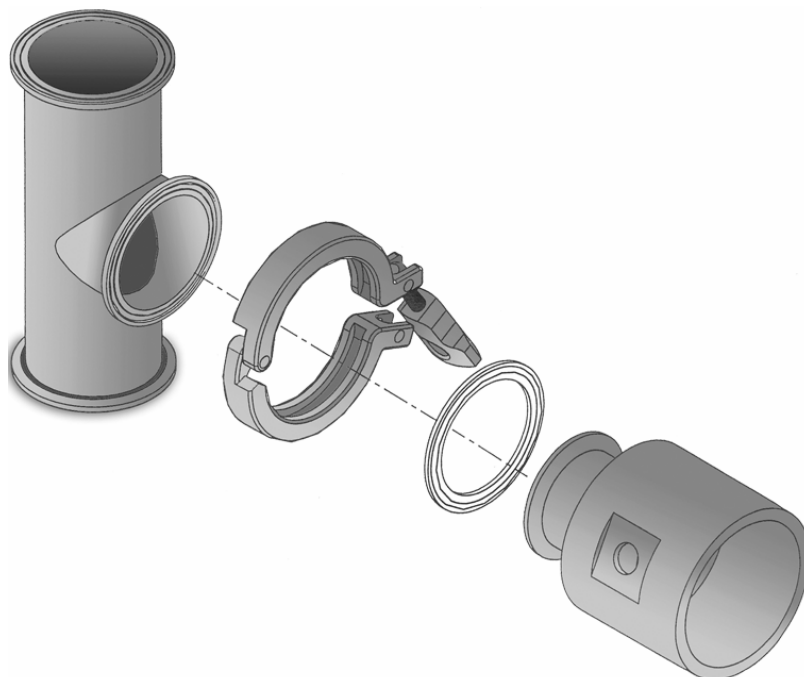

Warranty

The system meets or exceeds the stated specifications and all of components of KPS are guaranteed against failure and manufacturing defects for a period of one (1) year from the date of delivery. KEM is not responsible for any indirect damages resulting from the operation of KPS. For the guarantee to be valid the equipment must be installed and operated in accordance with the supplied Operation Manual, and within normal and specified conditions. KEM retains the right to either replace or repair any defective part. The warranty does not cover the sensor if alterations are made to it without prior written consent by KEM.

KEM
Küppers Elektromechanik GmbH
Liebigstr. 2
D-85757 Karlsfeld, Germany

Tel. +49 81 31/59 39 10
Fax +49 81 31/9 26 04
E-Mail: info@kem-kueppers.com
web: www.kem-kueppers.com

Copyright KEM, Zi Rev. 001/08/07