

Technical Datasheet



GFM High Resolution Series

High Resolution Gear Flow Meter
for the exact dosing and measuring of
extremely small quantities

Description

The special design of the GFM High Resolution series flow meters is tailored for measuring and dosing extremely small quantities. They are ideal as meters in test stands and for applications where great flexibility with optimum measuring performance is in demand. Lubricating as well as non-lubricating, abrasive, aggressive and filled media across a very broad viscosity range can be measured precisely and reliably.

The innovative GFM High Resolution flow meters combine the absolute measuring precision of proven gear flow meters with exceptionally high-resolution, compact, integrated electronics. The precise mechanical measuring element supports the most dynamic possible measuring range with the lowest possible activation point. Extraordinarily broad measuring ranges are realized and cascading fades into the background. The GFM High Resolution is therefore suitable for cost-reducing system designs and minimizes replacement part inventories.

Only high-grade steels and alloys that even withstand corrosive liquids are used in the production of GFM High Resolution flow meters. Combined with the use of tungsten carbide bearings, the GFM High Resolution guarantees optimum measurement accuracy and a long service life under even the toughest application conditions.

Stainless steel bearings guarantee smooth start-up behavior, even with very small volume flows and low-viscosity media. The combination of various gear dimensions and modules allows a wide range of sizes that can cover a huge measuring range.

Principle and Design

GFM High Resolution flow meters are positive displacement meters. Two precise gears rotate freely inside the measuring chamber.

Sealed cavities are created between the gears and the housing. The measured media causes the rotation of the gears. The flowing medium is distributed evenly in the measuring chamber and causes the rotation of the gears. The gear wheels rotate freely and undamped in the media flow. Their rotational frequency is proportional to the flow rate and is measured by non-intrusive sensors (pickups) through the housing wall. A variable magnetic field is generated in addition on the rotating gear, and is recognized and evaluated by a high-resolution hall element. Concrete resolutions up to 1,000,000 Imp/l can be generated from this through interpolation. The flow direction of the medium can also be derived and output.

Pulses per unit of volume are available for analysis. The calibration factor (K-factor) of the flow meter describes the exact pulse rate per unit of volume. In order to determine the individual calibration factor of a flow meter, we calibrate each of our meters in house prior to delivery. The operating viscosity specified by the customer is taken into account for calibration. A corresponding calibration certificate is included with every flow meter we supply.

The GFM High Resolution meters from KEM are suitable for accurate measurement of different liquids with viscosities of approximately 1 to 25,000 mm²/s. For low-viscosity media and fuels gear flow meters with ball bearings and reduced tolerances are used. Precisely measuring abrasive media is no problem thanks to highly robust tungsten carbide bearings.

Due to the high output frequency, good resolving capacity, and short response times, our GFM High Resolution flow meters are ideal for measuring very small quantities and suited for applications in dosing systems, test stands, and for all types of consumption measurement.

Applications

- Test stand applications
- Dosing of extremely small quantities
- Consumption monitoring and additive dosing
- Coating and PU applications
- Monitoring of dosing pumps and operating materials

Media

- Adhesives and sealants
- Paints and coatings
- Additives and catalysts
- Lubricants and preservatives
- Fuels and operating fluids

Features

- Measuring range up to 1:1000
- Extreme resolution up to 1,000,000 Imp/l
- Compact, integrated electronics
- Output signal for flow and direction
- High measuring accuracy up to $\pm 0.1\%$ ¹⁾
- Exceptional repeatability of $\pm 0.05\%$
- Short response times
- Pressure-resistant up to 250 bar [3,625 psi]
- Medium temperature up to 125 °C [257 °F]
- Explosion protection for Zone 2

¹⁾ Under laboratory conditions; incl. linearization; viscosity ≥ 30 mm²/s.

Series

GFM High Resolution flow meters are offered in two different series, differentiated mainly by the structure of the measuring kit.

Series A is equipped with high quality tungsten carbide bearings. These flow meters are especially well suited for measuring non-lubricating and abrasive media. Since tungsten carbide withstands abrasive media, reliable applications with extremely aggressive media are possible. Even highly filled media can be measured well with the A-series GFM High Resolution flow meters. Thanks to the finest tolerances, their penetration into the bearings is extremely limited and they have no negative impact on the start-up behavior and friction in the measuring kit.

Series B distinguishes itself through the use of high-precision stainless steel ball bearings and optimized tolerances of the measuring kit. These flow meters are used primarily for measuring clean, lubricating media. The ball bearings ensure minimum friction in the measuring kit. This makes it possible to realize extremely low activation points that are expressed in a very broad measuring range. Optimized tolerances minimize the internal leakage in the GFM High Resolution, so that the specified measuring accuracy can also be guaranteed for low-viscosity media.

In order to obtain the most accurate measured values, series A should be installed as vertically and series B as horizontally as possible.

Technical Data - Sizes

GFM High Resolution ²⁾	Extended Measurement Range (l/min)	Linearity Error Extended Measurement Range (Viskosität ≥ 30 mm ² /s)	Standard-Measurement Range (l/min)	Linearity Error Standard-Measurement Range (Viskosität ≥ 30 mm ² /s)
GFM 002 Series A	0.002 to 2.0	at 0.002 l/min: ±(0.5 % o.r. + 0.013 % f.s.)	0.01 to 2.0	±0.5 % o.r.
GFM 004 Series A	0.01 to 4.0	at 0.01 l/min: ±(0.5 % o.r. + 0.019 % f.s.)	0.02 to 4.0	±0.5 % o.r.
GFM 004 Series B	0.002 to 4.0	at 0.002 l/min: ±(0.5 % o.r. + 0.0068 % f.s.)	0.02 to 4.0	±0.5 % o.r.
GFM 004 Series B (Aluminum)	0.002 to 4.0	at 0.002 l/min: ±(0.5 % o.r. + 0.0068 % f.s.)	0.02 to 4.0	±0.5 % o.r.
GFM 010 Series A	on request	on request	0.1 to 10.0	±0.5 % o.r.
GFM 025 Series A	on request	on request	0.5 to 25.0	±0.5 % o.r.

GFM High Resolution ²⁾	Resolution approx. (Imp/l)	max. Frequency approx. (Hz)	max. Pressure (bar/psi)	Weight (kg)
GFM 002 Series A	60,000 120,000 240,000	2,000 4,000 8,000	250 [3,625]	1.3
GFM 004 Series A	30,000 60,000 120,000	2,000 4,000 8,000	250 [3,625]	1.6
GFM 004 Series B	250,000 500,000 1,000,000	17,000 25,000 (max. 3 l/min) 25,000 (max. 1.5 l/min)	80 [1,160]	1.6
GFM 004 Series B (Aluminum)	250,000 500,000 1,000,000	17,000 25,000 (max. 3 l/min) 25,000 (max. 1.5 l/min)	200 [2,900]	0.8
GFM 010 Series A	13,500 27,000 54,000	2,300 4,500 9,000	250 [3,625]	2.2
GFM 025 Series A	5,500 11,000 22,000	2,300 4,500 9,000	250 [3,625]	2.9

²⁾ Exact type designation see ordering code (page 6).

Technical Data – General

Measuring Accuracy	Up to $\pm 0.1\%$ ³⁾
Repeatability	$\pm 0.05\%$ (under the same conditions) Deviating in the extended measuring range
Materials	Housing: as per DIN 1.4305 [AISI 303], 1.4404 [AISI 316L], Aluminum (EN 7075) Gears: as per DIN 1.4122, 1.4501 [AISI F55] Bearing/Axis: Tungsten carbide or stainless steel ball bearing Seals: FKM, PTFE
Dimensions	See dimensional drawing (page 5)

Technical Data – Electronics

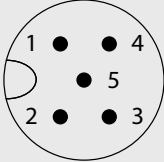
Electrical Output	Push-Pull, I max 20 mA
Supply Voltage	7 - 30 V DC
Quiescent Current	< 20 mA
Ambient Temperature	-40 °C up to +70 °C [-40 °F up to +158 °F]
Medium Temperature	non Ex: -40 °C up to +125 °C [-40 °F up to +257 °F] Ex, Zone 2: -40 °C up to +70 °C [-40 °F up to +158 °F]
Ingress Protection	IP66
Ex Protection	Zone 2: II 3G Ex nA IIC T4 Gc
Electrical Connection	5-pin plug M12; A coded 1 = +U _B 2 = signal for direction 3 = 0 V 4 = frequency signal for flow 5 = n.c. 

³⁾ Under laboratory conditions; incl. linearization; viscosity ≥ 30 mm²/s.

Dimensional Drawing

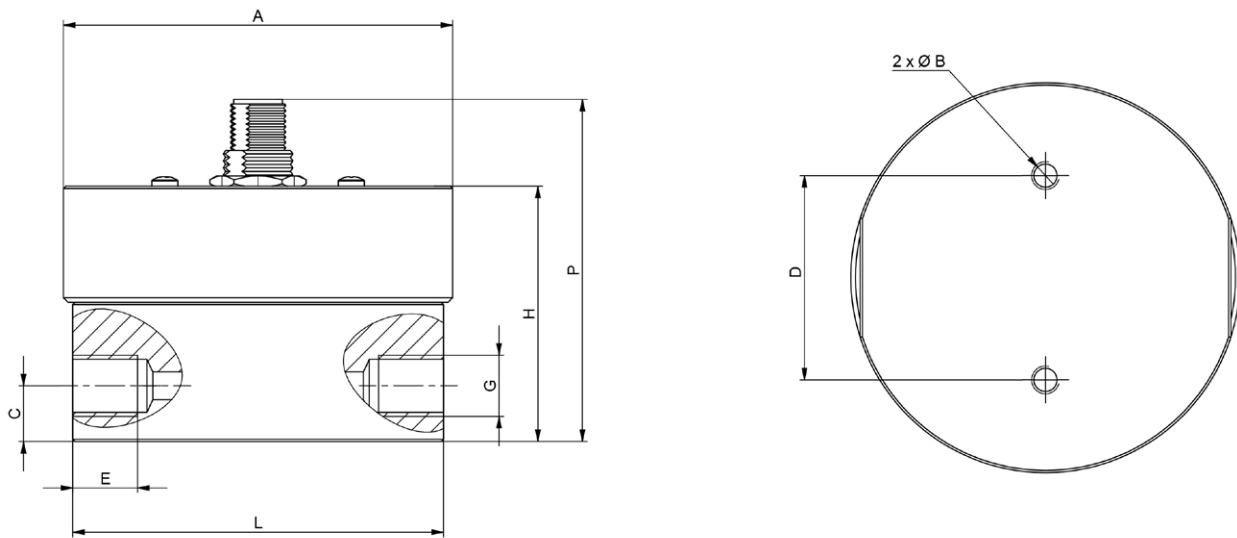

GFM High Resolution	Ø A	B	C	D	E	G	H	L	P
GFM 002	84 mm [3.3 in]	M6 ∇ 10 [M6 ∇ 0.41]	12 mm [0.47 in]	44 mm [1.73 in]	14 mm [0.55 in]	G $\frac{1}{4}$ "	55 mm [2.17 in]	80.5 mm [3.17 in]	73.7 mm [2.90 in]
GFM 004	84 mm [3.3 in]	M6 ∇ 10 [M6 ∇ 0.41]	12 mm [0.47 in]	44 mm [1.73 in]	14 mm [0.55 in]	G $\frac{1}{4}$ "	55 mm [2.17 in]	80.5 mm [3.17 in]	73.7 mm [2.90 in]
GFM 010	84 mm [3.3 in]	M6 ∇ 10 [M6 ∇ 0.41]	12 mm [0.47 in]	44 mm [1.73 in]	14 mm [0.55 in]	G $\frac{1}{4}$ "	55 mm [2.17 in]	80.5 mm [3.17 in]	73.7 mm [2.90 in]
GFM 025	84 mm [3.3 in]	M6 ∇ 10 [M6 ∇ 0.41]	12 mm [0.47 in]	44 mm [1.73 in]	14 mm [0.55 in]	G $\frac{3}{8}$ "	67 mm [2.64 in]	80.5 mm [3.17 in]	85.7 mm [3.37 in]

Safety Instructions

- The GFM must be grounded on the ground screw.
- Safety regulations for electrical equipment have to be followed.
- Commissioning and maintenance may only be carried out by qualified personnel.
- The media being measured must be free of ferromagnetic components.

Ordering Code

	GFM	-	XXX	-	X	-	X	-	XX	-	XX	-	X	-	X	X	XXXX	-	Exn
Measuring Range																			
Up to 2 l/min			002																
Up to 4 l/min			004																
Up to 10 l/min			010																
Up to 25 l/min			025																
Series																			
GFM Series A																			A
GFM Series B																			B
Bearing																			
Tungsten Carbide																			1
Stainless Steel Ball Bearing																			2
Material Housing/Gears/Bolts																			
1.4305 / 1.4122 / Steel 12.9																			05
1.4404 / 1.4122 / A4-70																			04
Aluminum (EN 7075) / 1.4122 / Steel 12.9																			70
1.4404 / 1.4501 / A4-70																			45
Connections																			
G 1/4" lateral																			GB
G 3/8" lateral																			GC
Sealing Options																			
PTFE O-ring																			T
FKM O-ring																			V
Electronics																			
Integrated Electronics																			I
Electrical Output/Connection																			
Push-Pull plug M12; 5-pin; A coded																			P
Resolution																			
1,000,000 Imp/l (only GFM 004 B)																			1000
500,000 Imp/l (only GFM 004 B)																			500
250,000 Imp/l (only GFM 004 B)																			250
240,000 Imp/l (only GFM 002 A)																			240
120,000 Imp/l (only GFM 002 A; GFM 004 A)																			120
60,000 Imp/l (only GFM 002 A; GFM 004 A)																			60
54,000 Imp/l (only GFM 010 A)																			54
30,000 Imp/l (only GFM 004 A)																			30
27,000 Imp/l (only GFM 010 A)																			27
22,000 Imp/l (only GFM 025 A)																			22
13,500 Imp/l (only GFM 010 A)																			13
11,000 Imp/l (only GFM 025 A)																			11
5,500 Imp/l (only GFM 025 A)																			5
Approvals																			
II 3G Ex nA IIC T4Gc																			Exn

Pressure Drop Curves

GFM 002

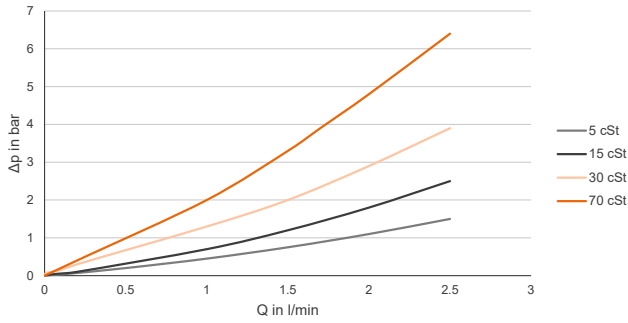

GFM 004

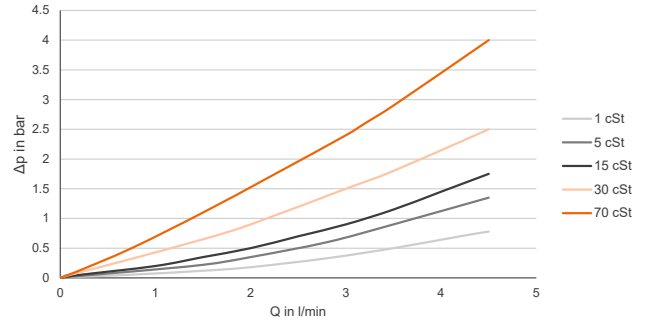

GFM 010

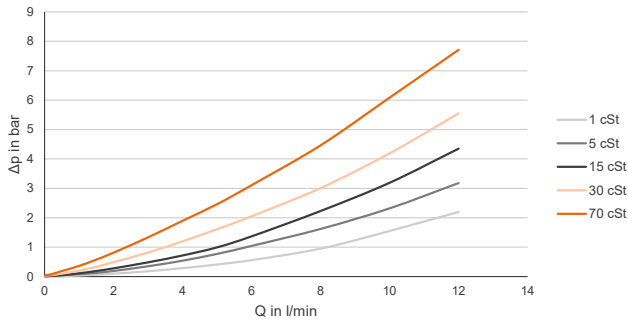

GFM 025

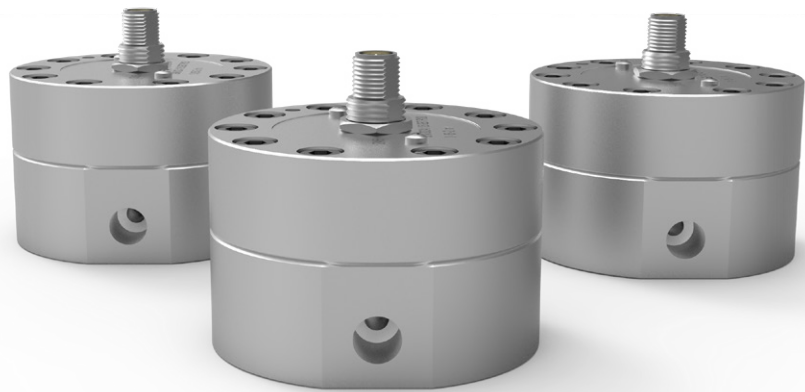
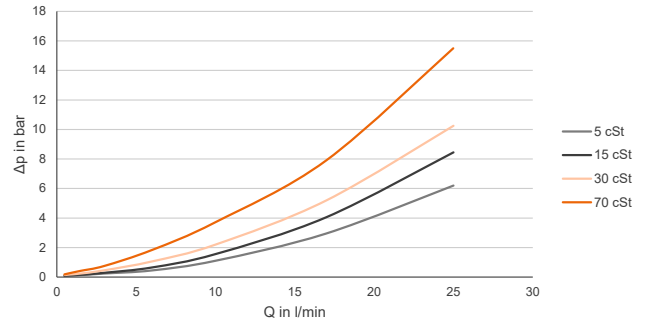

Calibration

In-house calibration is performed on volumetric calibration rigs or in our DAkkS calibration laboratory, depending on the needs of the client.

The KEM calibration lab uses a high-precision load cell system. With an accuracy of 0.05 % for the mass and 0.1 % for the volume of flowing liquids, we occupy a leading position worldwide. The German Accreditation Body (DAkkS) has accredited the laboratory engineers, processes and measuring equipment in accordance with the international standard DIN EN ISO/IEC 17025:2018.

The KEM calibration certificate not only verifies the accuracy of a flow meter, but also guarantees its traceability to national standards ensuring all requirements according to international quality standards are met.

The calibrations are performed with different hydrocarbons. This ensures the optimum simulation of changing operating conditions in density and viscosity even when temperatures change. This way the primary viscosity for the use of the flow meter can be specifically taken into account when viscosity fluctuations occur in a customised application.

The calibration result is the specified calibration factor (K-factor) in pulses per litre. This K-factor accordingly applies only at a certain flow velocity or a certain flow rate.

The calibration factor varies only very slightly at different volume flow rates. The individual measuring points provide the calibration curve of the flow meter from which the average K-factor is determined. The average calibration factor applies to the entire measuring range.

The linearity specification (percent deviation) refers to the average K-factor. To further increase the measurement accuracy in onsite use, the specific K-factors can be used to calculate the flow rate. For this, KEM also supplies optional special electronics.

Calculation of volume flow

The flow is directly dependent on the measured frequency and the associated calibration factor:

$$Q = \frac{f \cdot 60}{K} \text{ l/min}$$

Q = Volume Flow

f = Measuring frequency

K = Specific K-Factor

Calibration protocol

Example: GFM High Resolution 010

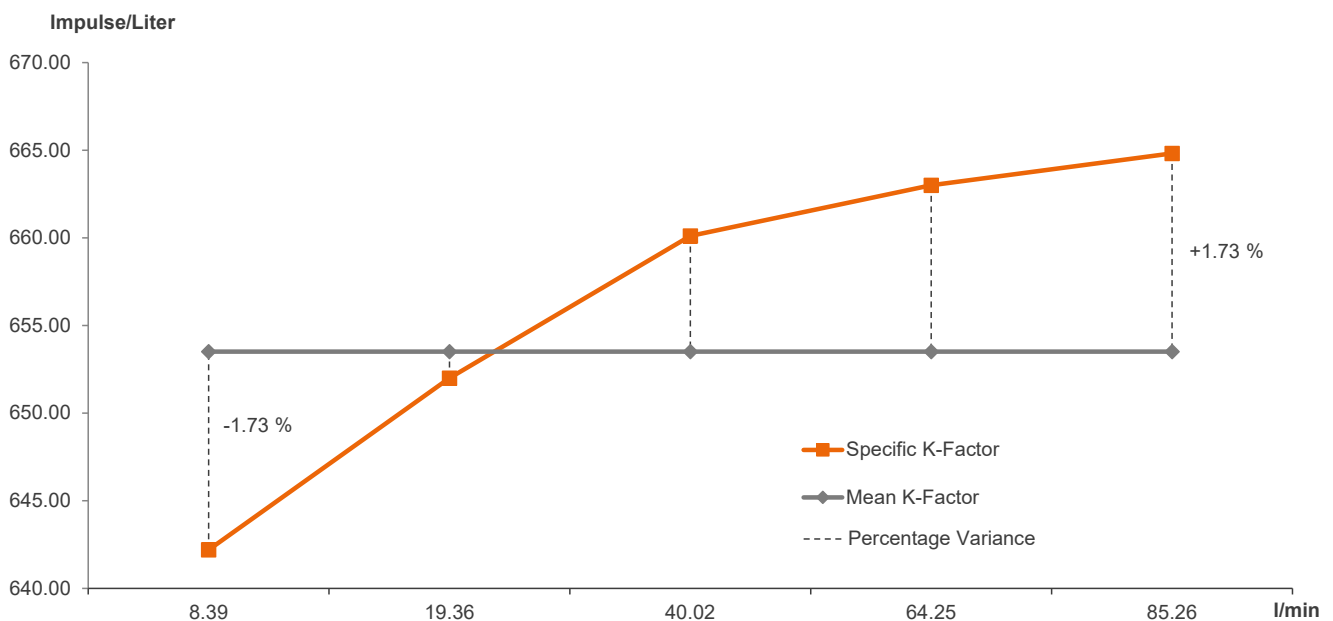



Küppers Elektromechanik GmbH

www.kem-kueppers.com

info@kem-kueppers.com

KEM Headquarters

Liebigstraße 5
85757 Karlsfeld
Germany

T. +49 8131 59391-0
F. +49 8131 92604

info@kem-kueppers.com

KEM Manufacturing Center

Wetzeller Straße 22
93444 Bad Kötzing
Germany

T. +49 9941 9423-0
F. +49 9941 9423-23

production@kem-kueppers.com

KEM Sales

Liebigstraße 5
85757 Karlsfeld
Germany

T. +49 8131 59391-100
F. +49 8131 92604

sales@kem-kueppers.com

KEM Service & Repairs

Wetzeller Straße 22
93444 Bad Kötzing
Germany

T. +49 9941 9423-37
F. +49 9941 9423-24

service@kem-kueppers.com

*More distributors & partners can be found at:
www.kem-kueppers.com*